

Name: _____		Date: _____		Event: _____	
City: _____		State: _____		Track: _____	
Track Conditions: <input type="checkbox"/> Indoor <input type="checkbox"/> Tight <input type="checkbox"/> Smooth <input type="checkbox"/> Hard Packed <input type="checkbox"/> Blue Groove <input type="checkbox"/> Wet <input type="checkbox"/> Low Bite <input type="checkbox"/> High Bite <input type="checkbox"/> Outdoor <input type="checkbox"/> Open <input type="checkbox"/> Rough <input type="checkbox"/> Loose/Loamy <input type="checkbox"/> Dry <input type="checkbox"/> Dusty <input type="checkbox"/> Med Bite <input type="checkbox"/> Other _____					

Front Suspension

Toe: _____

Ride Height: _____

Camber: _____

Caster: _____

Wheel Hex: _____

Sway Bar: _____

Piston/Oil: _____

Spring: _____

Limiters/Droop: _____

Steering Ackerman: _____

Bump Steer: _____

Camber Link: _____

Shock Location: _____

Receiver Battery Type: _____

Differentials

Front: Standard Smart

Spring Wire Dia: _____

Qty of Springs: _____

Ramp Plate: _____

Grease: _____

Diff Fluid: _____

Center: Standard Smart

Spring Wire Dia: _____

Qty of Springs: _____

Ramp Plate: _____

Grease: _____

Diff Fluid: _____

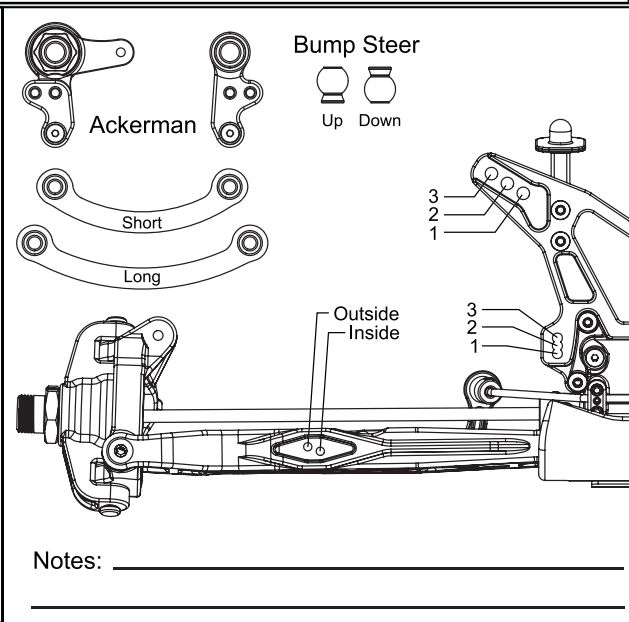

Rear Suspension

Roll Center: HRC LRC HRC Fwd/LRC Rear

Toe: _____

Anti-Squat: _____

Ride Height: _____

Camber: _____

Rear Hub Spacing: _____

Wheel Hex: _____

Sway Bar: _____

Piston/Oil: _____

Spring: _____

Limiters/Droop: _____

Camber Link: _____

Shock Location: _____

Rear Diff Fluid: _____

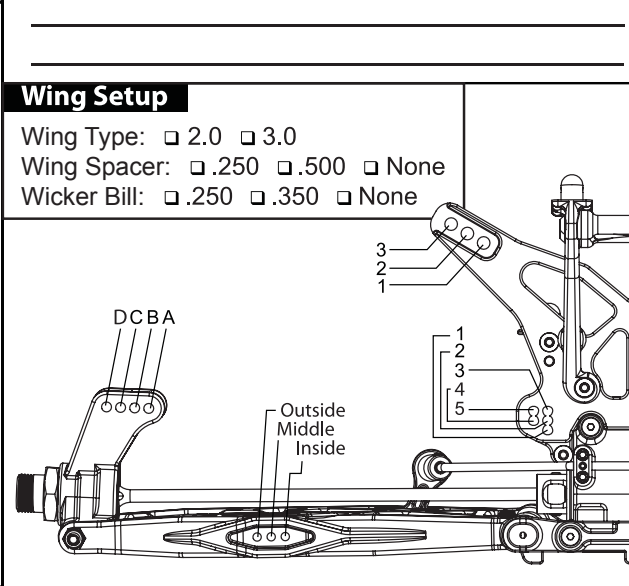

Electronics

Radio: _____ Timing Advance: _____

Servo: _____ Throttle/Brake Expo: _____

Pinion: _____ Servo Expo: _____

Spur: _____ Throttle/Brake EPA: _____

Initial Brake: _____ Motor: _____

Drag Brake: _____ Battery: _____

ESC: _____

Throttle Profile: _____

Tires

	Type	Compound	Insert
Front:	_____	_____	_____
Rear:	_____	_____	_____
Notes:	_____		